

JZ873 Low Power Wireless Module

User's Manual



About JZ873

JZ873, the Low power wireless module, is used as the wireless data transmission in short distance.

With the small size, weight and power consumption and good stability and reliability, it has the function of bi-directional data sign transmission, test and control.

It is used for Wireless meter reading, such as water meter, electric meter and gas meter, parking meter, intellectual card, electronic weighing apparatus, meter for checking on work attendance, queue wireless meter, building control, shipping company control, alarm system, intelligent equipment, Automatic data collecting system; Industrial remote control and remote test building automation, safety and security, powerhouse equipment wireless monitor, entrance control system, etc. It provide the USB power interface to be convenient

for the mini computer and PC users if necessary.

JZ873 Feature

1.Ultra low power transmission

Transmission power :500mW, high receiving sensitivity: -123dbm , size: 58mm*38mm*10 mm.

2. Low power consumption

Receiving current<45mA , transmission current<360mA , sleeping current < 1mA.

3. Saving power model

JZ873 have three saving power models: awoken from Hardware, awoken from COM Port, awoken from air (the user need to ask for it before place an order).

4.IO attemper function

JZ873 have 2 on-off input ports, 2 on-off output ports.

5. ISM frequency band, not requiring on application of frequency point

Carrier frequency of 433MHz , also capable of 868/915MHz.

6. High anti-interference and low BER (Bit error Rate)

Based on the GFSK modulation mode, it adopts the efficient communication protocol. The actual bit error rate of 10^{-5} ~ 10^{-6} can be achieved when channel bit error rate is 10^{-2} .

7. Long transmission distance

Within the range of visibility, the reliable transmission distance is (BER= $10^{-3}/1200\text{bps}$)>3000m, (BER= $10^{-3}/9600\text{bps}$)>2000m when the antenna height is greater than 3m (BER= $10^{-3}/9600\text{bps}$).

8. Transparent data transmission

Transparent data interface is offered to suit any standard or nonstandard user protocol. Any false data generated in the air can be filtrated automatically (What has been received is exactly what has been transmitted). The charge time for receiving and sending <10ms.

9. Multi-channel and speed

The standard JZ873 configuration provides 16 channels. to meet the multiple communication combination mode of the users. It has baud rate to be chosen such as 1200bps 、 2400bps 、 4800bps 、 9600bps 、 19200bps 、 38400bps. The wireless transmission rate is direct ratio with baud rate of interface to meet user's equipment requirement.

10. High speed wireless communication and large data buffer

When the speed rate in the air is quicker than interface's, allowing to transmit unlimited length data at one time, when the speed rate is slower or equal the interface's, allowing the transmission of 255 Bytes long data frames at one time for more flexible programming by users.

11. Intelligent data control and the user doesn't need to prepare excessive programs

Even for semi duplex communication, the user doesn't need to prepare excessive programs, only receiving/transmitting the data from the interface. JZ873 will automatically complete the other operations, such as transmission/receiving conversion in the air, control, etc.

12. High reliability, small and light

Single chip radio- frequency integrated circuit and single chip MCU are used for lessened peripheral circuits, high reliability, and low failure rate.

13. Watchdog monitor

Watchdog monitors the inner function, so that change the traditional product structure and improve the product reliability.

Application of JZ873

1.Appearance figure

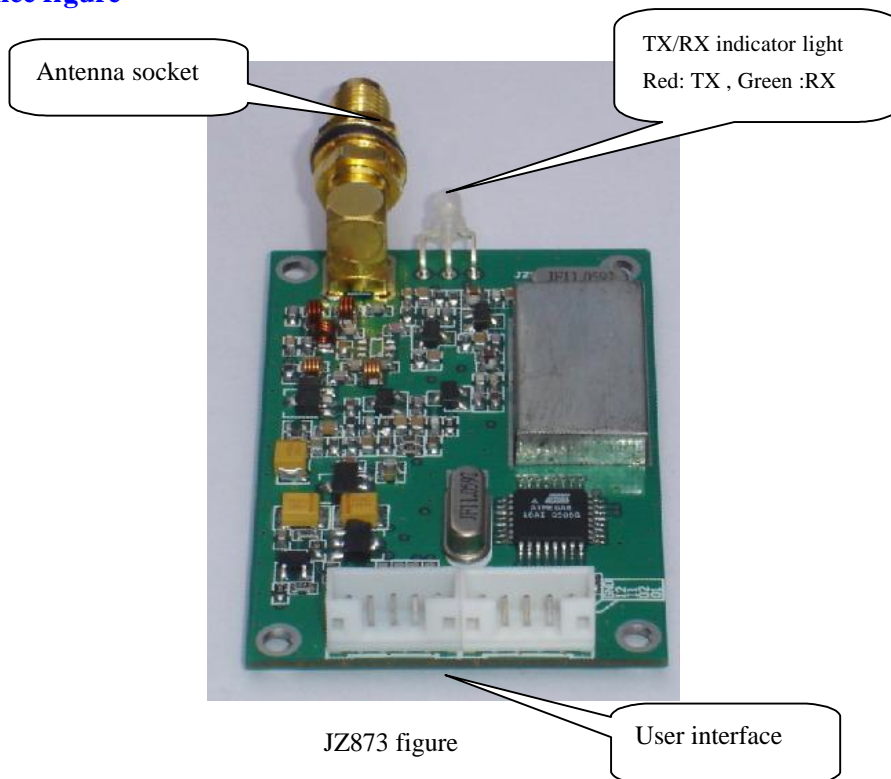

2.JZ873 interface definition

1) User's interface

JZ873 have one interface of TTL/RS232/RS485, user can choose one .

JZ873 standard interface: when the antenna upward , the plastic socket gap upward , from left to right,1-9 pin in turn , as below figure:

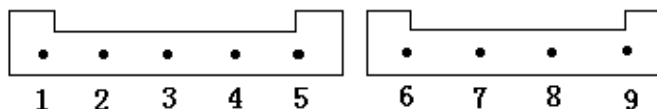

(Remarks: Jack space between is 2.0 mm.)

Definition of connecting pins and connection method:

Item no	PIN	Description Level Connected	User terminal	Remarks
1	SLE	Sleep control (input) end		Low level to sleep, High level awake
2	TXD/ A (RS-485)	Serial data transmitting end	RXD/ A (RS-485)	
3	RXD/ B (RS-485)	Serial data receiving end	TXD/ B (RS-485)	
4	GND	Power supply/Ground	DGND/AGND	
5	VCC	+5±0.5V	+5±0.5V	TTL 3V user's choose
6	I ₂	NO. 2 on-off input	user terminal on-off output	
7	I ₁	NO. 1 on-off input	user terminal on-off output	
8	O ₂	NO. 2 on-off output	user terminal on-off input	
9	O ₁	NO. 1 on-off output	user terminal on-off input	

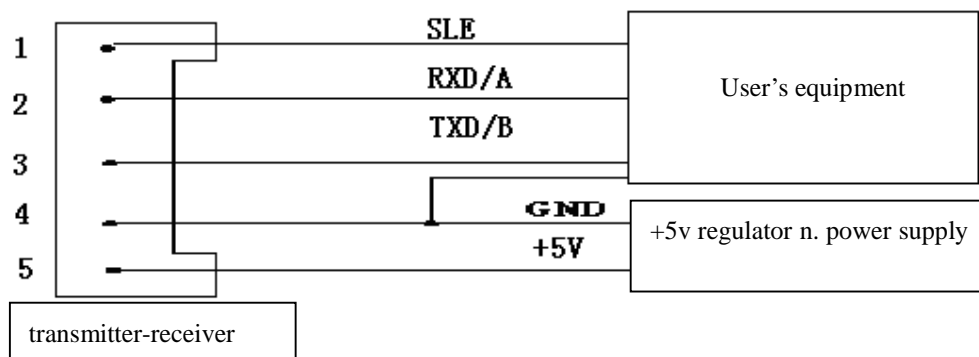

Remarks:

To avoid to connect the interface reverse and can not communicate, please check and assure the voltage of 2 and 3 pin is existing by using Multimeter. If there is one pin that has the voltage, another has not voltage, which means the interface is connected reverse, please change the connection wires between pin 2 and 3.

2) Power supply

JZ873 uses DC power supply with voltage of +5V. It can also share power supply with other equipment, however, the high quality power supply with desirable ripple factor should be selected. In addition, the reliable grounding must be used if there is other device in the system equipment. In case of failure to connect with the earth, it can form its own grounding, but it must be absolutely separated from the municipal electric supply.

3) Application of IO control

JZ873 have 2 on-off input ports , 2 on-off output ports , you can use as follow:

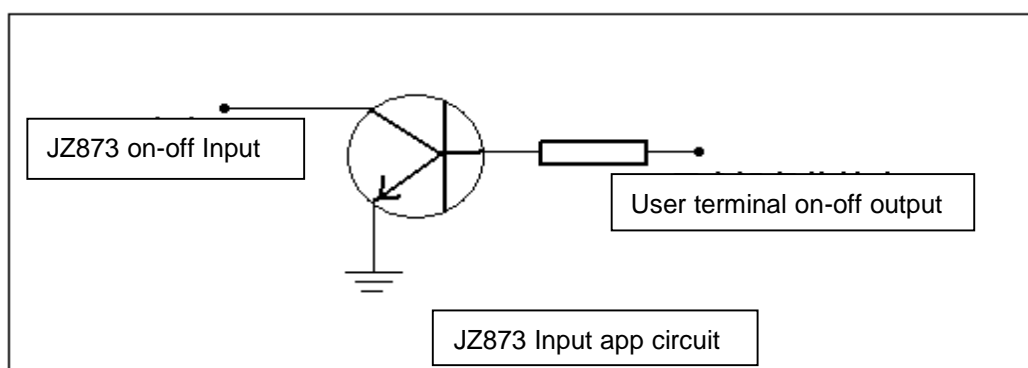
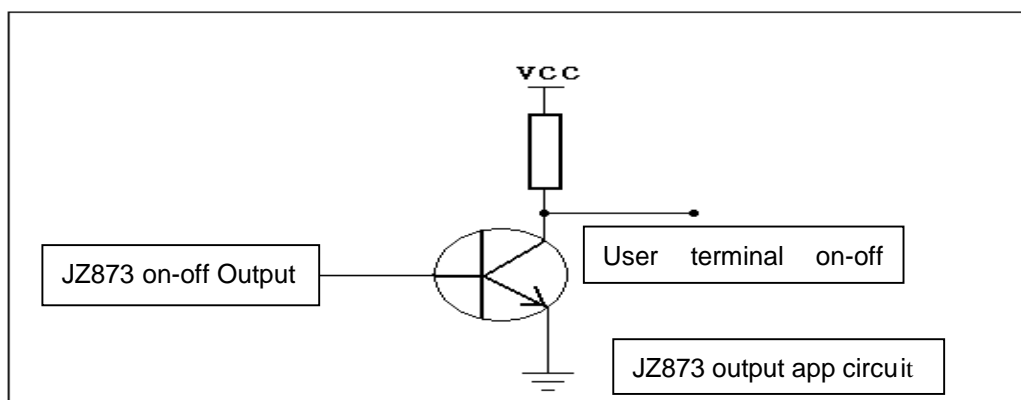

3.Saving power model

JZ873 have three Saving power models: awoken from Hardware, awoken from COM Port, awoken from Air. The model can be set by RF Module software. You can choose one saving power model, the default model is awoken from Hardware.

1) Awaken from Hardware:

When JZ873 sleeping in this saving power model, the current is under 100uA.

Sleeping status: when you input low level at NO. 5 pin, JZ873 can sleep. In this status, JZ873 cannot transmit and receive data.

Normal work status: when you input High level at NO. 5 pin, JZ873 turn into Normal work status, 10ms later, JZ873 can transmit and receive data.

Remarks: if you keep the NO. 5 pin untouched, then JZ873 in Normal work status.

2) Awaken from COM Port:

When JZ873 sleeping in this saving power model, the current is under 11mA. When you input data to

JZ873 with COM port, JZ873 turn into Normal work status after 10mS and can transmit the data. When JZ873 did not receive data in COM port in the period of 20 seconds, JZ873 will turn into sleep status.

3) Awaken from Air:

When JZ873 sleeping in this saving power model, the current is under 20mA. When JZ873 in this saving power status, JZ873 works intermittently. When JZ873 received awoken data from air, JZ873 will turn into normal work status after 10ms, it can receive data normally. When JZ873 did not receive data from air in the period of 20 seconds, it will turn into sleep. So when you wake up JZ873 from air, you can transmit some useless data firstly.

4 · IO Attemper Function

JZ873 have two communicate protocol: full transparence protocol and ID protocol.

(Remark: full transparence protocol is default protocol, if you need JZ873 with ID protocol, please tell us when you book)

1) Full transparence protocol

In this mode, whatever you use, any data frame, JZ873 can send it to another side as like as two peas, it cannot change data format and data bits. JZ873 with this transmit mode be used for Reading meter, RTU and PLC with Address itself and so on.

2) ID protocol

When your terminal without Address or ID, you can use JZ873 with ID protocol , in this way you can differentiate the data from you terminal. The Main station you must use JZ873 with full transparence protocol,

the appurtenant station you must use JZ873 with ID protocol. The JZ873 of the appurtenant station must set ID according our RF module software, you can resolve the data from user terminal transmit according to ID Protocol.

Remark: when you use JZ873 with ID protocol, we provide 《communication protocol of JZ873》 and programme manual.

3) IO attemper function

You can use one JZ873 with full transparence protocol for the Main station, some JZ873 with ID protocol for the appurtenant stations, each JZ873 of the appurtenant station must set one unrepeatable ID. You can attemper the appurtenant station IO according to communication protocol of JZ873.

Remark: when you use IO attemper function, we provide 《communication protocol of JZ873》 and programme manual.

JZ873 parameters setting

JZ873 have one interface of TTL · RS232 · RS485, You must specify the interface when you buy. JZ873 main parameters: COM baud rate and verify · RF baud rate, Channel and frequency ° You can change these parameters by our RF Module soft. When RF baud rate is faster than COM baud rate ·One frame Can transmit limitless data. When RF baud rate is not faster than COM baud rate One frame Can transmit 255 bytes most. You can set the rate according your need. The general Power supply is 5V DC.

Two JZ873 communicate must have condition as follow:

- 1.Their channels (i.e. frequency) are the same.
- 2.Their RF rates are the same.
- 3.RF Module Com baud rate and verify is agree with its equipment or PC that it connects with.

Parameters default value:

Channel : 1

Interface speed rate : 9600BPS

Interface verify : none

Speed rate in air : 9600BPS

Channel and frequency list

Channel	Frequency	Channel	Frequency
1	430.2000MHZ	9	458.5250MHZ
2	431.4288MHZ	10	459.1250MHZ
3	431.7360MHZ	11	459.5250MHZ
4	430.5072MHZ	12	460.1250MHZ
5	434.6940MHZ	13	460.5250MHZ
6	434.2332MHZ	14	461.1250MHZ
7	433.1580MHZ	15	461.5250MHZ
8	433.9260MHZ	16	462.1250MHZ

Technical specification of JZ873

Modulation mode: GFSK
 Working frequency: 433MHZ
 Transmission power: <500mW
 Receiving sensitivity: -123dBm
 Transmitting current: <360mA
 Receiving current: <45mA
 Sleeping current: <1mA
 Channel speed rate: 1200/2400/4800/9600/19200/38400Bit/s, User can Choose one
 Interface speed rate: 1200/2400/4800/9600/19200/38400Bit/s, User can Choose one
 Change time for receiving and sending: <10ms
 Interface data format: 8E1/8N1/8O1
 Power supply: 5±0.5V DC
 Working temperature: -20°C ~ 85°C
 Working humidity: 10% ~ 90% relative humidity without condensation
 Dimension: 58mm*38mm*10 mm
 Attachable Communication with Model: JZ871/JZ872/JZ873/JZ878

Model and name

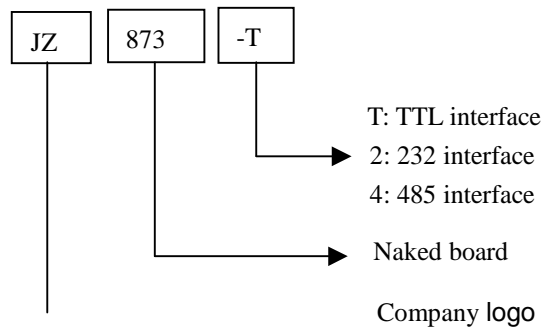



Optional Antenna:



Trouble and solve ways:

NO.	Trouble	Trouble causes and solve ways
1	No shine of Indicator light	a 、 Power Line badness touch . b 、 Power is bad. c 、 Power line meet in reverse, or diode of polarity protect is bad.
2	No transmit or No receive	a 、 Radio is badness touch with PC/terminal. b 、 Radio with TTL/RS232/RS485 not match terminal. c 、 RX frequency and TX frequency is not same.
3	Bit error rate High	a 、 antenna not match, or touch bad; b 、 RF baud rate is not right. c 、 Power supply ripple is too great.
4	Indicator light twinkling	a 、 Electromagnetism disturb in circumstance. b 、 Same frequency disturb in the circumstance.